



WATER PRESSURE BOOSTER SYSTEMS

POSI-BOOST



Model PB5050

APPLICATION

Applications include residential, commercial, industrial and other installations requiring a boost in water pressure. The economical NECO Posi-Boost System will efficiently provide a steady downstream pressure regardless of a varying flow rate and/or varying inlet pressure.

DESIGN FEATURES

- Single source responsibility
- Professionally engineered components
- Available in constant speed or variable speed (Energy Efficient)
- Factory assembled and tested
- Compact design minimizes floor space
- Easy to install & start-up

Neco's other packaged & customized systems include:

- Water Pressure Booster
- Sewage Lift Stations
- Boiler Feed Systems
- Elevator Sump Pumps with oil sensors
- Packaged Chilled Water and Hot Water Circulating Systems
- Condensate Return Units
- Geothermal Circulating Systems
- Rain Water Harvesting Systems
- Heat Transfer Systems
- Fuel Oil Pump Sets

Visit us on the web ~ www.necosystemsinc.com

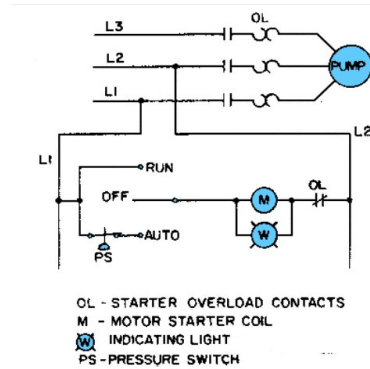
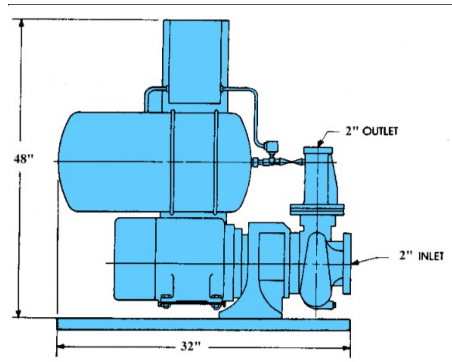
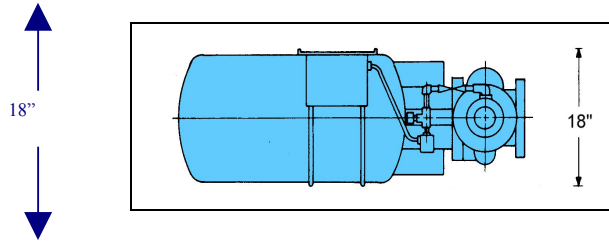

OPERATING CONDITIONS	PB2035 *	PB2540	PB5050	PB7550	PB10050
Pump Horsepower	1	2	3	5	7.5
Max. Flow GPM	20	25	50	75	100
Max. Boost PSI	35	40	50	50	50
Min. Suction Pressure PSI	2	2	2	2	2
Max. Suction Pressure PSI	35	55	50	50	50
Shipping Weight LBS	45	300	310	360	375
Available Voltages	115/230/60/1	208-230/460 115-208/230/1	208-230/460 115/230/1	208-230/460 230/1	208-230/460 230/1

MAXIMUM WORKING PRESSURE 125 PSI

* No Tank Included

SUGGESTED SPECIFICATIONS

Furnish and install a POSI-BOOST simplex water pressure booster system as manufactured by **NECO Pumping Systems, Inc.**, of Souderton, PA (215-721-2200). The packaged and tested system shall be complete with a bronze fitted pump, epoxy coated pressure regulator, NEMA 1 pump controller and a hydro-pneumatic tank for no flow shut down. The packaged pumping system shall be factory assembled and tested with type "L" copper piping and shall include pressure gauges. It shall be cleaned and painted with a high grade enamel prior to shipment.

Contact us today to discuss your design requirements.

Neco's other packaged & customized systems include:

- Water Pressure Booster
- Sewage Lift Stations
- Boiler Feed Systems
- Elevator Sump Pumps with oil sensors
- Packaged Chilled Water and Hot Water Circulating Systems
- Condensate Return Units
- Geothermal Circulating Systems
- Rain Water Harvesting Systems
- Heat Transfer Systems
- Fuel Oil Pump Sets

Visit us on the web ~ www.necosystemsinc.com