



PORTABLE WATER PRESSURE BOOSTER PUMP PACKAGE

NECO's portable Water Pressure Booster Package was initially designed and used to provide water for military field showers; although it is ideally used anywhere additional water pressure is required on a temporary basis.

The Basic package is capable of providing constant pressure of 40psi with a flow of 100 gpm using a single pump controlled by a variable frequency drive controller. A standard Hubble connector with a 20 foot power cable for 208 Volt 3 phase power is provided.

Should only single phase power be available the Variable Frequency Controller will automatically convert the single phase power source to 3 phase for the motor.

Weighing less than 150lbs., the package is lightweight compared to fix location packages and can be moved by two people. A drawing of the package is on the reverse side of this datasheet.

The package is ready to use and requires a single power connection along with suction and discharge connections. The package is designed to withstand outdoor environments

STANDARD FEATURES

- Closed coupled bronze fitted end suction pump for 110gpm @ 40psi
- 5HP 208V/60/3 TFEC motor
- Suction & discharge connections are 1-1/2" CAMLOK connections
- Yaskawa IQPump Variable frequency pump controller 208V 3 phase or 230V 1 phase
- 10 Gallon Hydro-pneumatic expansion tank
- 1- 2" Check Valve
- 2- 2" ball valve
- 1- hose bib
- 1- Steel Frame for mounting and protection of the pumping components
- Operation with single or three phase power

Neco's other packaged & customized systems include:

- Water Pressure Booster
- Sewage Lift Stations
- Boiler Feed Systems
- Elevator Sump Pumps with oil sensors
- Packaged Chilled Water and Hot Water Circulating Systems
- Condensate Return Units
- Geothermal Circulating Systems
- Rain Water Harvesting Systems
- Heat Transfer Systems
- Fuel Oil Pump Sets

Visit us on the web ~ www.necosystemsinc.com

Neco Systems, Inc. • 458 E. King Road • Malvern, PA 19355 • Tel.: 215.721.2200 • Fax: 610.648.0880

Rev 13-04



NECO
SYSTEMS INC.

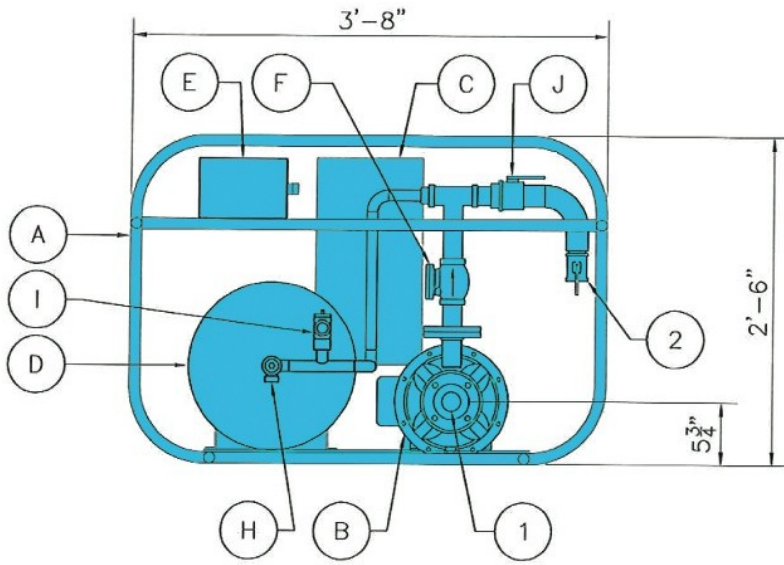

FRONT VIEW

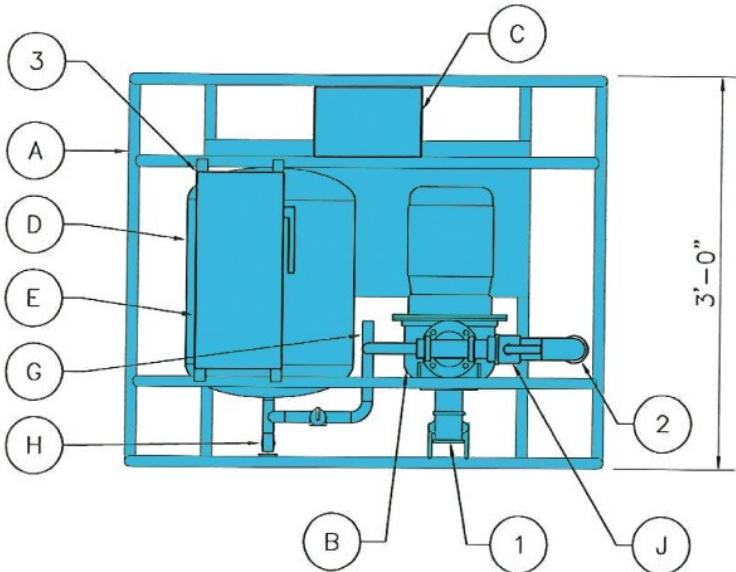

PLAN VIEW

SYSTEM DESCRIPTION							
MODEL No: 4SHAV1N4/PCS-FAB							
NOMINAL WEIGHT: 125 LB							
PUMP No.	MANUFACTURER	MODEL NUMBER	GPM	TDH	HP	RPM	
P1	GOULDS PUMPS	4SH2J52D0(5.5)	145	81	--	--	
ELECTRICAL DATA: 208-230V 3PH TEFC							
SPECIAL MOTOR REQ: NONE							
BILL OF MATERIAL							
ITEM NO.	DESCRIPTION	QUANTITY					
A	1" DIA STEEL	1					
B	SSH CLOSE COUPLED END SUCTION PUMP	1					
C	V.F.D.	1					
D	HYDRO-PRO WATER SYSTEM TANK	1					
E	NEMA 3 R DISCONNECT SWITCH	1					
F	2" CHECK VALVE	1					
G	300 PSI TRANSDUCER	1					
H	DRAIN VALVE	1					
I	PRESSURE RELIEF VALVE	1					
J	2" BALL VALVE	1					
FIELD CONNECTIONS							
ITEM NO.	DESCRIPTION	QUANTITY					
1	2 1/2" FEMALE CAMLOK WATER INLET	1					
2	2" FEMALE CAMLOK WATER DISCHARGE	1					
3	ELECTRICAL CONNECTION 208-230 3PH	1					

	DRAWN BY: B-CAD CHECKED BY: AK DATE: 4/23/16	TITLE: --- MOBILE BOOSTER SIZE: A FROM NO: --- ENG. NO: --- REV: 0
APPROVED BY: --- DATE: --- SCALE: NONE SHEET 1 OF 1		

Neco's other packaged & customized systems include:

- Water Pressure Booster
- Sewage Lift Stations
- Boiler Feed Systems
- Elevator Sump Pumps with oil sensors
- Packaged Chilled Water and Hot Water Circulating Systems
- Condensate Return Units
- Geothermal Circulating Systems
- Rain Water Harvesting Systems
- Heat Transfer Systems
- Fuel Oil Pump Sets

Visit us on the web ~ www.necosystemsinc.com

Neco Systems, Inc. • 458 E. King Road • Malvern, PA 19355 • Tel.: 215.721.2200 • Fax: 610.648.0880